



**Power
Transmission**



Quick, easy and precise

Hydraulic hub-shaft connections



ETP-TECHNO®

High precision and frequent mounting



ETP-TECHNO is a hydraulic connection with very high precision. It is especially designed for applications where fast frequent changes or adjustments, with high precision are needed. It can be mounted/dismantled 1000's of times.

ETP-TECHNO is very easy to mount with only one screw, and it also has extremely good concentricity.

ETP-TECHNO is the one to choose among the ETP hub-shaft connections when very high precision is needed.



ETP-TECHNO is a hydraulic connection for high precision and frequent mounting. Available as standard for shafts 15 - 130 mm, also imperial. Runout $\leq 0,006$ mm.

Number of mountings 500 - 5 000 (size dependent). It has an extra seal consisting of a steel ball at the end of the piston, which is pressed against a spherical seating when mounted. ETP-TECHNO is often used as a base for special and customised solutions.

Construction

ETP-TECHNO is a hydraulic connection which consists of a double-walled hardened steel sleeve filled with a pressure medium, and a flange. The flange contains the pressure screw and piston with dual sealing function - an o-ring plus backup ring and a steel ball.

Operation

When the pressure screw is tightened, the double-walled sleeve expands uniformly against the shaft and the hub and creates a rigid joint. Dismantling of the joint is simply done by loosening the screw. ETP-TECHNO returns to its original measurements and can easily be dismantled.

When the pressure screw is tightened to the recommended tightening torque, T_t , the steel ball seals against the spherical seating. ETP-TECHNO will create a uniform surface pressure against the shaft and hub.

Benefits and features

- Extremely fast mounting/dismantling with only ONE screw.
- Can be mounted/dismantled 1000's of times.
- Extremely good concentricity, ≤ 0.006 mm, also after several mountings.
- Dual sealing system.
- Radial tightening of the screw saves space along the shaft.
- Small built-in dimensions.
- Accurate positioning, no axial movement when mounting.

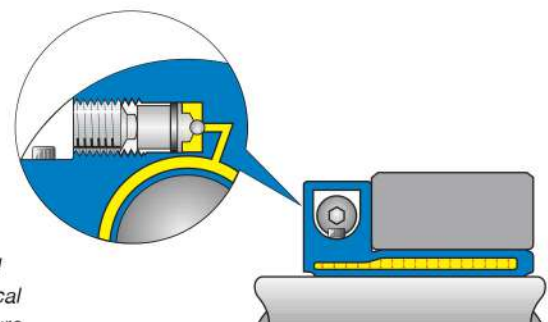

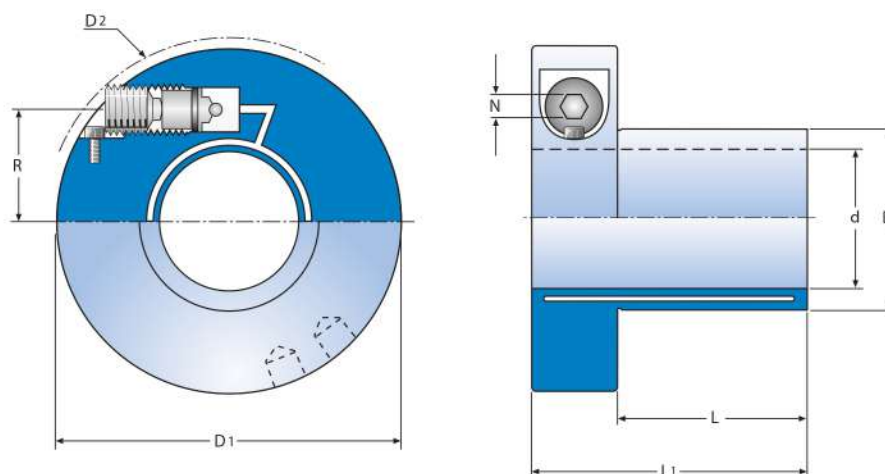

Notation: ETP-TECHNO XXX

Technical specification ETP-TECHNO®

ETP-TECHNO®	Dimensions						Transmittable			Screws				Polar moment of inertia J $\text{kgm}^2 \cdot 10^{-3}$	Weight kg
	d mm	D mm	D ₁ mm	D ₂ * mm	L mm	L ₁ mm	torque T Nm	axial force F _A kN	radial force F _R kN	Dim.	R mm	N mm	T _t Nm		
15	15	19	52	53	25	41	50	5	1	M12	16	6	10	0,09	0,25
20	20	25	59	60	30	46	145	12	2	M12	19	6	10	0,15	0,32
25	25	32	70	71	35	55	250	16	3	M14	24	6	16	0,38	0,58
1"	25,4	32	70	71	35	55	250	16	3	M14	24	6	16	0,38	0,58
30	30	38	75	79	40	60	500	26	4	M14	26	6	16	0,54	0,69
1 1/4"	31,75	41	79	81	42	62	510	25	4	M14	27,5	6	16	0,64	0,78
32	32	41	79	81	42	62	510	25	4	M14	27,5	6	16	0,64	0,78
35	35	44	84	87	45	65	740	34	5	M16	29,5	8	24	0,75	0,84
1 1/2"	38,1	50	90	93	50	70	880	36	5	M16	32,5	8	24	1,1	1,08
40	40	52	91	95	55	75	1200	47	6	M16	33	8	24	1,3	1,18
45	45	56	96	101	58	78	1700	62	7	M16	35	8	24	1,5	1,24
50	50	65	110	114	60	85	2250	71	9	M20	40,9	10	40	2,3	1,64
60	60	75	125	132	70	95	4400	119	12	M20	46,8	10	40	5	2,51
70	70	90	140	149	85	110	7000	158	13	M20	53	10	40	8,9	3,65
75	75	95	147	158	90	115	8600	183	14	M20	55,3	10	40	12	4,20
80	80	100	156	168	95	123	10900	218	15	M22	58,7	10	60	15	4,85
90	90	112	166	177	105	133	15500	277	17	2 x M22**	63,3	10	60	22	5,44
100	100	125	177	188	115	143	21000	335	19	2 x M22**	70	10	60	33	6,18
110	110	138	187	197	125	153	28000	410	21	2 x M22**	75,5	10	60	43	7,08
120	120	150	198	208	135	163	29000	393	23	2 x M22**	81,1	10	50	54	9,96
130	130	163	208	217	135	163	32000	393	25	2 x M22**	86,8	10	46	75	10,86

T= Transmittable torque when axial force is 0. } When the screw/screws is tightened to T_t.
 F_A=Transmittable axial force when torque is 0.
 F_R=Max transmittable radial force at continuous operation.
 Max allowed bending torque: 10% of transmittable torque T.

T_t= Recommended tightening torque for the screw/screws.
 Further tightening does not increase the pressure.
 *) D₂ is valid before mounting.
 **) Pressure screws positioned in the same direction.
 Dimensions subject to alterations without notice.

Tolerances
 Shaft h8.
 Hub H7.

Type of torque

Transmittable torque, T, is for static load.
 If the load is alternating or pulsating torque, reduce the transmittable torque, T, with the following factors: (factor x T).
Alternating: 0,7 x T.
Pulsating: 0,8 x T.

For further information see section Technical information/Design tips, page 52-55.