



**Power
Transmission**



Quick, easy and precise

Hydraulic hub-shaft connections



ETP-HYLOC[®]

For heavy loads and quick mounting

ETP-HYLOC is a hydro-mechanical hub-shaft connection which, due to its robust design, is ideally suited to work in difficult environments and heavy operations like steel rolling mills, process industries etc. An interesting application, among many, has been fastening of feeding or forming rolls to shafts. ETP-HYLOC is fast to mount, has good concentricity and can take high torque and radial loads. Mounting and dismantling is easily carried out with a hydraulic pump.





ETP-HYLOC is available as standard for shafts 50 - 220 mm. Runout $\leq 0,02$ mm. Number of mountings: Max. 2 000. Customized models for shaft > 220 mm can also be offered on request.

For extreme high torque applications the contact surfaces of ETP-HYLOC (sizes ≥ 100 mm) can be plated with ETP-HFC, High Friction Coating, which doubles the torque capacity.

Construction

ETP-HYLOC is a hydro-mechanical joint, which consists of a double-walled steel sleeve which encloses a conical moveable piston. Mounting and dismantling is carried out with a hydraulic pump. In the flange there are three threaded connections ("ON", "P" and "OFF") in the radial direction and the same in the axial. This makes it possible to choose radial or axial connection of the pump hoses, depending on the build-in situation.

Operation

When the piston is moved, by the hydraulic pressure from the pump, the double-walled sleeve expands uniformly against shaft and hub to form a rigid joint. When dismantling, the piston is moved in the opposite direction and the joint will loosen. A small amount of oil will be taken via spiral tracks in the piston between the surfaces (pressure applied through the "P" connection), in this way making it easier for the piston to move. Normal working pressure is 1 000 bar.

Benefits and features

- High transmittable torque capacity - can be varied by changing the mounting pressure.
- Fast mounting/dismantling in tight spaces.
- High radial load capacity.
- Radial and axial connection is possible.
- Fine adjustments of the hub can be made when mounting.
- Good concentricity, also after several mountings.
- With ETP-HFC coating – double torque capacity.

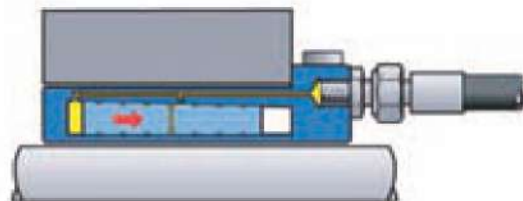

Mounting: apply pressure in the "ON" and "P" (not shown) connections. When mounted no hydraulic pressure remains. The small conical angle prevents the piston from releasing.

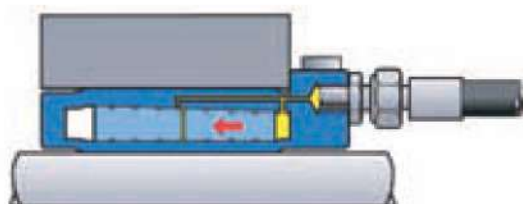

Dismantling: apply pressure in the "OFF" and "P" (not shown) connections. ETP-HYLOC returns to its original measurements and the joint is loose.

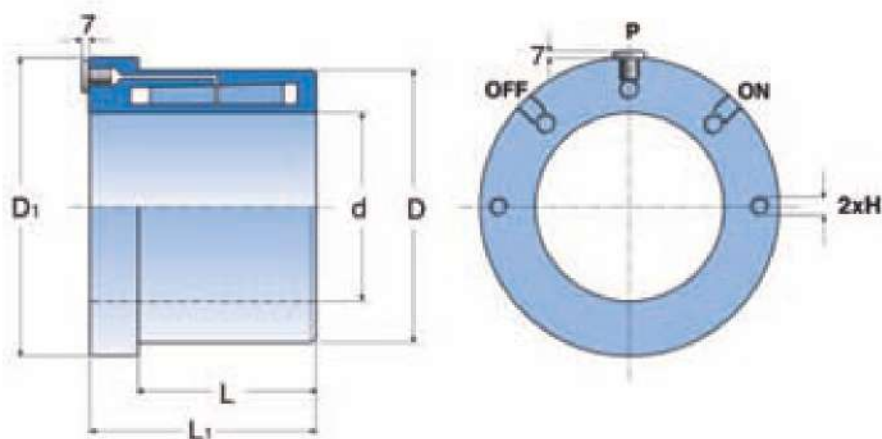

Notation: ETP-HYLOC XXX

Technical specification ETP-HYLOC®

ETP-HYLOC®	Dimensions					Transmittable torque or axial force at 1000 bar						H	Polar moment of inertia J kgm ² · 10 ⁻³	Weight kg
						Shaft h7		Shaft h8		Min hub DH mm				
	d mm	D mm	D1 mm	L mm	L1 mm	T kNm	F _A kN	T kNm	F _A kN	Yieldpoint N/mm ² >300	Yieldpoint N/mm ² >400			
50	50	77	101	56	82	2,6	70	2,4	70	110	105	M8	3,2	2,4
60	60	89	113	64	90	4,6	130	4,3	130	140	125	M8	5,4	3,1
70	70	102	122	74	100	7,9	210	7,4	200	170	145	M8	8,7	4,1
80	80	115	135	84	110	12,1	290	11,5	280	200	160	M8	14	5,4
90	90	128	148	94	120	17,1	380	16,2	360	235	180	M12	23	7,0
100	100	140	160	104	130	24,2	485	23,1	460	270	200	M12	34	8,6
110	110	154	173	114	140	32,9	595	31,5	570	295	220	M12	51	11
120	120	168	186	124	150	43,2	720	41,6	690	320	240	M12	76	14
130	130	182	200	134	160	53,8	825	51,4	790	350	260	M16	110	17
140	140	196	213	144	170	68,9	985	66,2	945	375	280	M16	150	21
150	150	210	227	154	180	85,4	1135	82,3	1095	400	300	M16	210	25
160	160	224	240	164	190	104	1305	100	1260	425	320	M16	290	30
180	180	252	267	184	210	150	1675	146	1625	480	360	M16	500	42
200	200	280	293	204	230	206	2060	200	2000	535	400	M16	830	56
220	220	308	320	224	250	273	2485	266	2415	585	435	M16	1300	73

ETP-HYLOC®	600 bar			800 bar			1200 bar					
	Shaft		Min. hub DH	Shaft		Min. hub DH	Shaft		Min. hub DH			
	h7	h8		h7	h8		h7	h8				
	T	T	Yieldpoint	T	T	Yieldpoint	T	T	Yieldpoint			
kNm	kNm	N/mm ²	kNm	kNm	N/mm ²	kNm	kNm	N/mm ²				
50	0,8	0,8	90	90	90	1,6	1,4	95	90	3,3	3,1	130
60	1,1	1,1	115	105	95	3,3	3	120	110	5,9	5,6	155
70	2,4	2,4	135	120	110	5,8	5,3	140	125	9,9	9,5	170
80	5,6	5,3	155	140	130	9	8,4	165	140	15,3	14,6	190
90	8,3	7,4	180	160	145	12,7	11,8	185	160	21,6	20,6	215
100	12,1	11	200	170	160	18,2	17,1	210	180	30,3	29,2	235
110	16,8	15,4	220	195	180	24,8	23,5	235	195	41	39,6	260
120	22,3	20,6	240	215	195	32,7	31,1	255	215	53,7	52	280
130	27,2	24,9	260	230	210	40,5	38,1	275	230	67	64,7	305
140	35,6	32,9	285	250	225	52,3	49,6	295	250	85,6	82,9	325
150	44,5	41,4	300	265	240	65	61,9	315	265	105	102	350
160	54,8	51,2	320	285	260	79,5	76	335	285	129	125	370
180	80	75	360	320	290	115	110	375	320	186	181	415
200	109	103	400	355	320	157	151	420	355	254	248	465
220	144	137	440	390	355	209	201	460	390	338	330	510

Transmittable torque at different mounting pressures.
The torque for sizes ≥100 can be increased by using ETP-HFC®

T = transmittable torque when axial force is 0.
F_A = transmittable axial force when torque is 0.
DH = Outer diameter for hub material in steel.
H: Threads for easy handling.
Dimension subject to alterations without notice.

TOLERANCES

Shaft h7 or h8

Hub H7

MOUNTING – ADVICE The contact surfaces L and L1 must be completely covered by the shaft and hub. The oil for the pump should be a transmission oil type 80 W. For other hub materials, for example aluminium, contact us.

MOUNTING PRESSURE The mounting pressure is normally 1000 bar. Max mounting pressure 1200 bar. Dismantling requires approx. 200 bar higher pressure than for mounting.

ETP-HYLOC can be designed to suit special applications on request, and also larger sizes are available.

For further information see section Technical information/Design tips, page 52-55.